OWNER'S MANUAL



P.O. Box 1520
Sykesville, MD 21784-1520
(410) 549-6083
Fax: (410) 549-6082

**Manufacturing High Quality, High Efficiency
Heat Pump Pool Heaters**

TABLE OF CONTENTS

SAFETY CONSIDERATIONS	2
INSPECTION	2
GENERAL INFORMATION	2
INSTALLATION	2
WATER FLOW & CONNECTIONS	2-3
ELECTRICAL CONNECTIONS	4
MODES OF OPERATION	5
WIRING DIAGRAMS	6
ELECTRONIC CONTROL PANEL	7
CHEMICAL USE	8
START-UP	9-10
MAINTENANCE	10-11
TROUBLESHOOTING CHECKLIST	11-12
CALLING FOR SERVICE	12
WARRANTY	13
WARRANTY REGISTRATION	14

ALL IN-GROUND MODELS

INSTALLATION, OPERATION, MAINTENANCE & SERVICE

SAFETY CONSIDERATIONS

- Qualified personnel should perform installation, maintenance and service.
- Make sure all field wiring conforms to the heater specifications and all national and local codes.
- Disconnect all power sources before performing any maintenance or service to the heater.

INSPECTION

Immediately upon receipt, inspect cartons and their contents for damage due to transit. Damage, if found, should be noted on delivery papers and a claim filed with the carrier. Also, check unit data plate to make sure you have the proper model, before installing.

GENERAL INFORMATION

The information in this manual was prepared to assist in the proper installation, operation, maintenance and service of your new heat pump pool heater. Please read the entire manual and follow all instructions. Improper installation and use can result in damage to the heater, unsatisfactory operation, and may void the warranty. Retain this manual for quick reference.

INSTALLATION

When selecting a location consider the following:

- Heater must be located outdoors.
- Minimum of 24” of clearance on access / service side of heater.
- Minimum of 18” of clearance on all three air intake sides of heater.
- Minimum of 48” of clearance for air discharge (top of unit).
- The heater should sit on a solid level surface sufficient above grade to prevent water from entering it, and allowing condensate to drain from base.
- The length of water piping and electric should be kept to a minimum to avoid capacity loss and decreased efficiency.

WATER FLOW & CONNECTIONS

Water connections are made at the rear of the heater. Both water in and out are labeled just above the water connections. LEFT REAR = WATER IN and RIGHT REAR = WATER OUT. 2” unions are supplied and are made to accept 2” rigid PVC pipe. NOTE: unions can be used for quick drainage of your heater and winterizing.

- Heater must be piped downstream from filter in the pool return line.
- **Inline chlorinators must be piped downstream from heater. A check valve must be installed between the heater and chlorinator to prevent drain back of the chlorine when the pump is off. A chemical trap may also be piped at least six (6) inches above the**

height of the chlorinator.

- When all the plumbing connections are complete, and ample drying time is allowed, run the filter pump and check the entire system for water leaks.
- Make sure filter is clean and there are no obstructions in the filtering system.
- Proper water flow is essential to the performance of your heater. The minimum flow rate is 20 GPM.

TYPICAL WATER FLOW CONNECTIONS

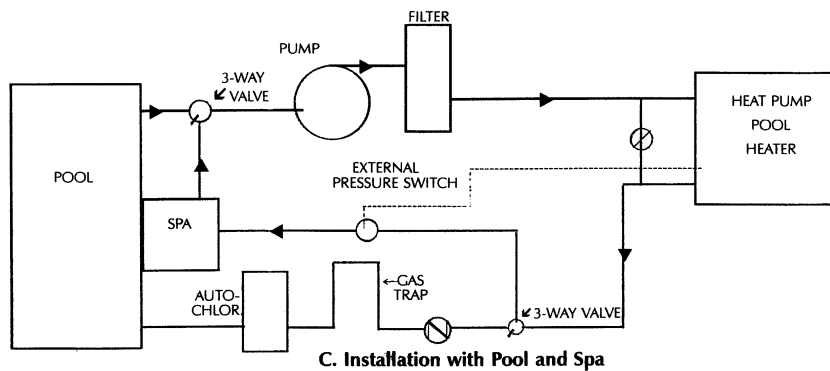
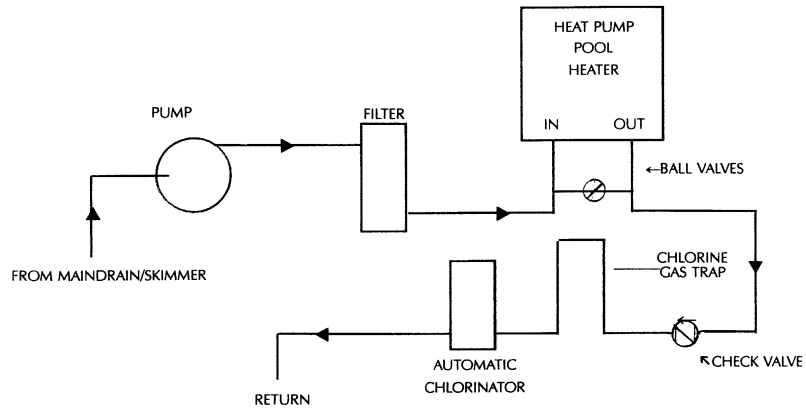
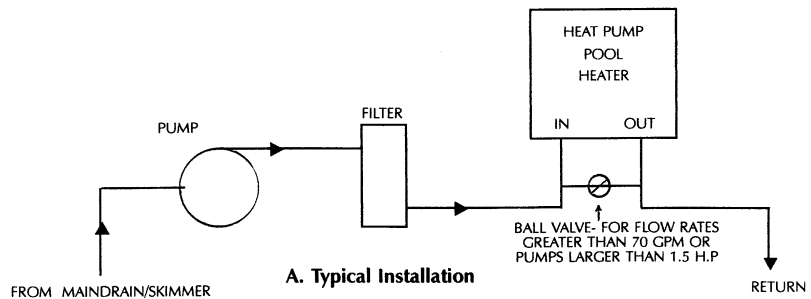

ELECTRICAL CONNECTIONS

Field connections must comply with national and local codes. The work must be done by a qualified electrician.

Heater must be permanently grounded and bonded.

Bonding will drastically reduce the chances of electrolysis, "Electrical Corrosion."

Use copper conductors only.

Disconnect all power sources before performing any work on unit.

Standard Power Supply: 208/230 - 60 - 1

See unit data plate for specific ampacity.

Wiring Main Power Supply

1. Remove the screws from lower left and right side of front cover (service panel).
2. Remove the screws on left side of hinged electrical enclosure.
3. Route weather tight flexible conduit through opening at base of unit. Connect conduit to the bottom of the electrical enclosure using a weather tight fitting. A knockout is provided next to the main contactor to accept a weather tight fitting. Mounting conduit directly to the electrical enclosure will ensure a moisture tight seal, extending the life of the heater.
4. Attach grounding conductor to the ground lug provided inside the electrical enclosure (labeled).
5. Install L1 and L2 input conductors to the line side of the main contactor. (See wiring diagrams.)
6. Connect bond wire (at least #8 solid copper wire) from bond lug on right side of coil header plate to pool pump bonding terminal or other suitable location.

MODES OF OPERATION

To Change Between Pool and Spa Set Points Automatically:

This change can be done automatically as the water flow is either directed to the pool or spa. The use of an external water pressure switch in the spa piping **IS** necessary. A two-wire control circuit must be connected from the water pressure switch to terminals 18 and 19 on the electronic control board. The red jumper wire at the top of the control board must then be cut to activate this system.

Remote Thermostats and Controllers:

If a remote thermostat or any other control system is to be used to turn the heater on and off, a normally open dry contact can be made at terminals 18 and 19 on the bottom right of the electronic control board. The red jumper at the top of the control board must then be cut to activate this system. In the case of a remote thermostat where the temperature will be regulated externally, set the Pool Mode to the OFF position and the Spa Mode to 104°F (40°C). The heater will only run when the remote control calls for heating.

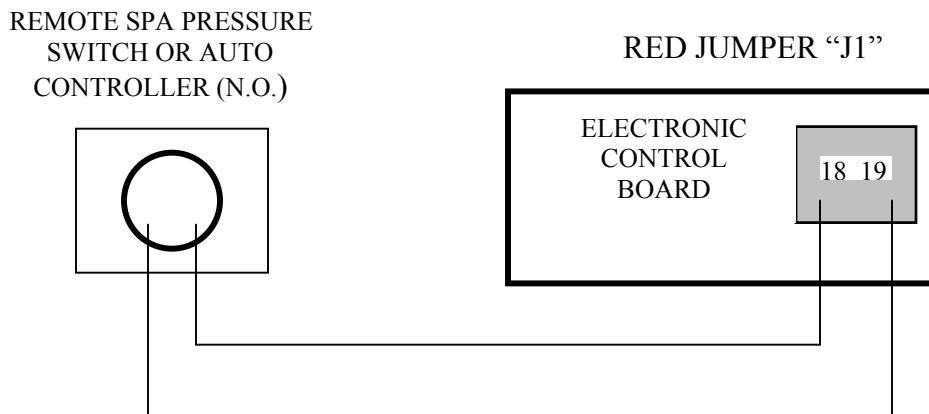

2 METHODS CAN BE USED TO SWITCH UNIT BETWEEN POOL AND SPA MODE.

J-1 JUMPER - NOT CUT: Using the select key will activate either mode manually.

J-1 JUMPER - CUT: A remote switch connected to terminals 18 and 19 will activate SPA MODE.

WIRING DIAGRAMS

208 / 240Vac 60Hz

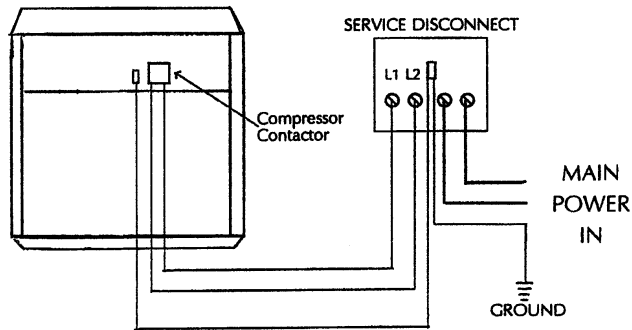
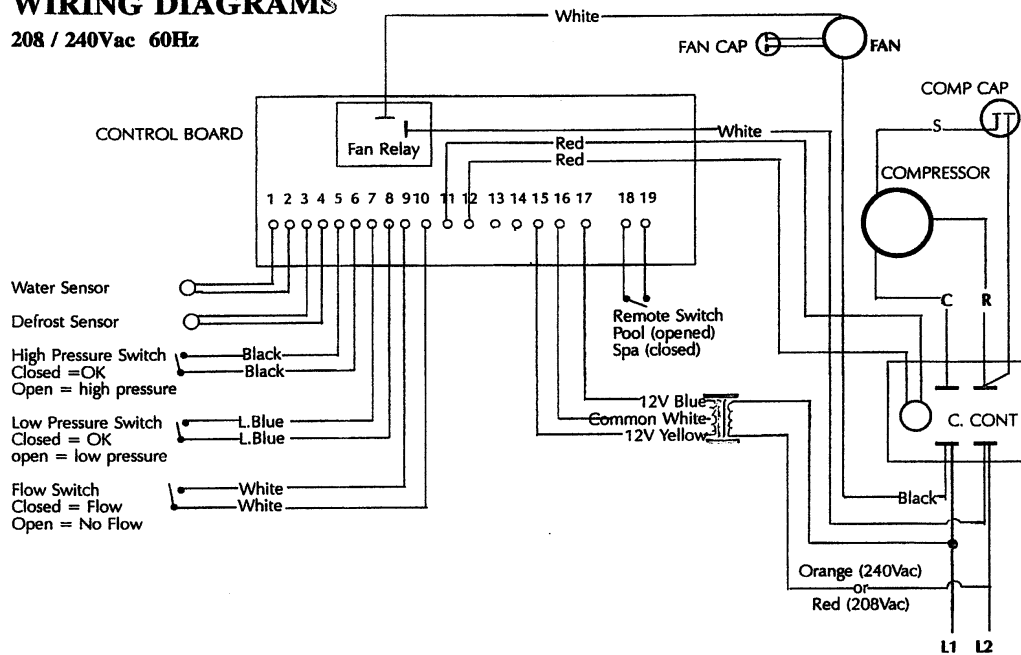

FIELD WIRING DIAGRAM

NOTES

1. USE COPPER CONDUCTORS ONLY.
2. CONNECT FIELD WIRING IN GROUNDED RAINTIGHT CONDUIT, PER RATING PLATE.
3. CONNECT BOND WIRE TO POOL STEEL USING #8 SOLID COPPER WIRE OR LARGER.
4. ALL WIRING MUST CONFORM TO NATIONAL (N.E.C.) AND LOCAL ELECTRICAL CODES.

ELECTRONIC CONTROL PANEL

DIGITAL DISPLAY

Displays the actual pool/spa temperature. In select mode displays other parameters.

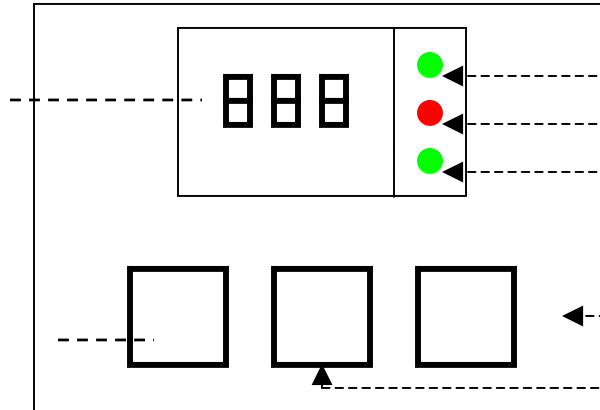

POOL LED indicates pool mode.
HEAT ON LED indicates heat is on.
SPA LED indicates spa mode.

SELECT/SERVICE KEY

Used to select mode of operation and enter service mode.

▲ INCREASE KEY

▼ DECREASE KEY

MODE SELECTION

Selecting the desired mode of operation is accomplished by pressing the SELECT KEY.

Temperature Setpoint

- Temperature setpoint maximum for POOL mode is 95°F (35°C).
- Temperature setpoint maximum for SPA mode is 104°F (40°C).

To change the temperature setpoint, press the SELECT KEY until you reach either POOL or SPA. This will prompt the control to display the current temperature setpoint. Hold either the UP or DOWN key to scroll your desired temperature setpoint. Once your new temperature setpoint has been reached, release the UP or DOWN key. Your new setpoint will be displayed for five seconds, then revert back to the actual pool or spa water temperature.

Selecting Pool or Spa Mode

Press the SELECT KEY until you reach P_S. Pressing the UP or DOWN key will allow you to enter either POOL or SPA mode. Green LED indicator lights will verify the mode selected.

FIL MODE MUST BE IN THE OFF POSITION OR A FLO3 ERROR CODE WILL BE DISPLAYED.

Selecting temperature in Fahrenheit or Celsius

The factory setting is Fahrenheit. Press the SELECT KEY until you reach F_C. Press the UP KEY to reach Fahrenheit or the DOWN KEY to reach Celsius.

CHEMICAL USE

Water quality must be checked regularly and maintained within recommended limits at all times. Failure to maintain the proper water quality will greatly reduce the life of your heater.

- Never add chemicals directly into skimmer.
- Automatic chlorinators must be piped downstream from the heater. A check valve must be installed between the chlorinator and heater to prevent raw chlorine from draining back into the heater. A chemical trap may be piped at least six (6) inches above the chlorinator. See piping diagram B.

Always maintain the following water quality requirements:

PH LEVEL 7.4 to 7.8
CHLORINE CONCENTRATION 1 to 5 PPM
TOTAL ALKALINITY 100 to 200 PPM
CALCIUM HARDNESS 100 to 300 PPM

START-UP

Before proceeding with this section make certain all plumbing connections are airtight and leak free.

Flow rates should not exceed 70 GPM maximum. Use of an external bypass is necessary at 70 GPM and above. Minimum flow rate is 20 GPM.

- Turn filter pump time clock to the ON position and set filter pump hours. For initial heating, the pool heater and filter pump may need to run continuously until your desired temperature is reached. After initial heating is achieved, the heater will run only to maintain your desired temperature.
- Turn power supply to heater ON.
- The control panel will light up and display either OFF or the actual pool water temperature.
- Select POOL or SPA and set your desired water temperature by scrolling either up or down.
- Select P_S and scroll up or down to select POOL or SPA mode.
- If your programmed water temperature is above the actual water temperature, the red HEAT ON LED will light up indicating HEAT mode. The fan will start, and then the compressor will start.

NOTE: Each time the compressor turns off, it is protected by a 3 minute anti-cycling delay.

Initial Heating

Initial heating may require you to run your heater and filter pump continuously for at least 24 hours, or more, depending on the following factors:

- Temperature difference between actual water temperature and desired water temperature.
- Size of pool.
- Ambient air temperature, the cooler the air temperature the longer the heating time.
- Heat loss (evaporative, convective, radiative and conductive).
- A pool cover / solar blanket may reduce initial heating time by up to 50 percent.

Reducing Heat Loss - Pool Cover / Solar Blanket

We highly recommend the use of a pool cover / solar blanket. Covering your pool is the single most cost effective means of reducing heat costs from 50 to 70 percent. Heating a pool without a cover is like heating a house without a roof. They also reduce the amount of maintenance costs. By reducing evaporation, covers reduce the quantity of chemicals needed.

Because evaporation accounts for about 70 percent of pool heat loss, the beneficial effect of using a pool cover / solar blanket can be dramatic.

Wind Speed Reduction

Reducing wind velocity at the water surface reduces convective and evaporative losses. Fences, trees, hills, or tall hedges close to the pool perimeter are effective windbreaks. Locate these obstructions to take maximum advantage of their effectiveness as windbreaks, without shading the pool surface from the sun.

Defrost Cycle

The heat pump pool heater has automatic defrost. When the outdoor temperature drops below 40 °F, frost may start to form on the evaporator coil. Frost buildup will be heaviest on humid days when the temperature is between 35-40°. During the defrost cycle, the display will show “FS” to indicate that the unit is defrosting. During this time the fan is running and the compressor is inactive.

Internal Protection Analyzers

The heater is equipped with internal devices to monitor and protect the integrity of the unit. Should an abnormal condition occur, these devices will interrupt the operation of the unit and may display the appropriate code on the control panel.

- **LOW WATER FLOW:** Indicated by “HP”, “HP3”, or “FLO” on the control panel. The heater is designed to run efficiently above twenty (20) GPM. If there is insufficient water flow, the unit will shut down, protecting the compressor. The usual causes for these conditions are a dirty pool water filter, a restriction in the return line (i.e. skimmer), or improper valve positioning.
- **NO WATER FLOW:** Indicated by “FLO” on the control panel. When the filter pump is off, or if the water flow to the heater is interrupted during the heating mode, the internal water pressure switch will shut down the unit. When normal water flow resumes, the heater will automatically restart itself.
- Other analyzer codes include: “FL3”, “LP3”, “LP”, “dPO”, “PO”, “dPC”, “Pc”, “PLE”, “CSE” and “SPi”.

The TROUBLESHOOTING CHECKLIST on page 11 goes into further detail on these analyzer codes.

MAINTENANCE

WARNING: DISCONNECT ELECTRICAL POWER TO UNIT BEFORE STARTING ANY MAINTENANCE TO PREVENT SERIOUS INJURY FROM SHOCK.

Protecting your Heater

- Keep your pool filter system clean and free of restrictions to ensure proper water flow.
- Check water chemistry regularly. Misuse of chemicals will cause permanent damage to your heater and other pool equipment. Manufacturers can void warranties for damage as a result of poor water quality.
- Free airflow is essential. Keep the evaporator coil clean and free of weeds, leaves, glass clippings, dirt and other debris that will decrease the airflow. Keep fences and shrubs away from air inlets (sides and back of heater).
- Frequent rinsing of the evaporator with fresh water will remove build up from its surface. Always spray the coil gently with a regular garden hose being careful not to bend aluminum fins.
- Regular cleaning of the cabinet will improve its appearance and extend the life of the finish.

Winterizing

When the heater is exposed to freezing temperatures, it is essential that all water within the unit be properly drained. When water freezes, it expands, damaging piping.

- Turn thermostat settings to OFF. Turn filter pump to OFF.
- Turn power to unit OFF (i.e. pull disconnect or turn circuit breaker OFF).
- Disconnect water inlet and outlet unions at the back of the unit. Be careful not to lose rubber o-rings.
- Flush the heater piping out with fresh water to remove any residual chemicals.
- Use low-pressure air or vacuum to remove water that has accumulated inside the piping of the heater.

TROUBLESHOOTING CHECKLIST

- Check to see that the electrical power is on. Reset breakers, or replace fuses if necessary.
- Check to be sure the electric control panel is set properly. The desired temperature must be set above the actual pool or spa temperature for the heater to run.
- Check to make sure the evaporator coil has enough clearance and that there are no restrictions to its airflow.
- Certain ambient air conditions may cause the heater to go into defrost mode, displayed on the control panel as “FS”.

NOTE: IT IS NORMAL FOR WATER TO DRIP FROM THE DRAINHOLES AT THE BASE OF THE HEATER. THE UNIT PRODUCES CONDENSATE WHEN IT OPERATES.

Analyzer Codes

FAILURE LOCK-OUT: This feature is for the protection of the heater. If the same failure occurs three (3) times within an hour, the control will not allow the unit to restart, and shall display the appropriate code (i.e. “FL3”, “HP3”, or “LP3”). The reset to normal conditions can be accomplished by pressing a button on the control touch pad.

“FLO” (Little or No Water Flow)

- The pump is not running.
- The filter is dirty or clogged.
- Shortage of water to pump - air leak.
- Undersized pump.
- Valves not in correct position.
- Filter in backwash mode.
- Water pressure switch needs adjustment, or is defective.

“FL3” (See page 6)

“HP” (Compressor High Pressure)

- Low water flow to heater.
- Defective high-pressure switch.

“LP” (Compressor Low Pressure)

- Evaporator coil dirty.
- Fan motor not running.
- Low refrigerant pressure.
- Defective low-pressure switch.

“dPO” Evaporator temperature sensor connection opened. Check for cut or loose sensor wiring or defective sensor.

“PO” Water temperature sensor connection opened. Check for cut or loose sensor wiring or defective sensor.

“dPC” Evaporator temperature sensor connection shorted. Check for a short in sensor wiring or defective sensor.

“Pc” Water temperature sensor connection shorted. Check for a short in sensor wiring or defective sensor.

“FS” Heat pump in defrost cycle.

“PLE or CSE” EEPROM memory data loss. Hold down the SELECT key until the error message disappears. The control will be reinitiated to factory default. Re-enter the setpoints.

“SPi” Defective controller, remove power and restart. If error is still present, replace controller.

CALLING FOR SERVICE

- Please eliminate any water flow problems before calling for service.
- If you are unable to contact the installing agent, please contact *AQUA COMFORT TECHNOLOGIES, LLC*. A factory representative will assist you or your serviceman over the phone.

SERVICE PERFORMED WITHIN THE WARRANTY PERIOD MUST BE APPROVED BY AQUA COMFORT TECHNOLOGIES, LLC PRIOR TO SERVICE BEING PERFORMED AND ONLY BY AN AQUA COMFORT TECHNOLOGIES, LLC AUTHORIZED TECHNICIAN. SEE WARRANTY FOR DETAILS.

Please have the following ready before calling:

IN-GROUND MODEL #:

SERIAL #:

DATE OF INSTALLATION:

NAME OF OWNER:

ADDRESS:

CONTACT #:

NATURE OF PROBLEM:

LIMITED WARRANTY HEAT PUMP POOL HEATERS

AQUA COMFORT TECHNOLOGIES, LLC (ACT) warrants only to the original owner, the HEAT PUMP POOL HEATER to be free of defects in materials and workmanship for a limited ten (10) year term as follows: One (1) year full parts and labor, years two (2) through ten (10) the compressor and heat exchanger (part only). This warranty does not include transportation charges for equipment or component parts to or from the factory. This warranty is valid only in the Continental U.S. The labor for repair or replacement of defective parts will be provided by ACT subject to the conditions of this limited warranty.

THE EFFECTIVE DATE OF WARRANTY is the date of installation, if properly documented, otherwise the date of manufacture plus three (3) months.

THIS WARRANTY WILL NOT APPLY TO: A) Malfunction or damage resulting from installation, operation, maintenance, voltage conditions, or service not in accordance with ACT specifications. B) Malfunction or damage due to the failure to perform normal maintenance as outlined in the Owner's Manual. C) Malfunction or damage due to conditions not intended for original use of the unit. D) Malfunction or damage due to negligence, abuse, freezing conditions, accident, or acts of God. E) Malfunction or damage from plants or animals. F) Malfunction or damage from the attachment of accessories not authorized by ACT. G) Unnecessary service calls due to erroneous operational reports, maintenance and electrical service. H) Units sold outside the continental United States.

SERVICE PERFORMED WITHIN THE WARRANTY PERIOD must be approved by ACT **PRIOR** to service being performed, and must be performed by an authorized technician. The warranty is void if the unit is repaired by anyone unauthorized by ACT. Reimbursement for replacement parts or repair services that are not authorized or performed by ACT are not covered under this limited warranty.

WARRANTY PARTS will be replaced or repaired at the discretion of ACT. Shipping of warranty parts is not included. Defective parts must be returned to ACT within the warranty period for validation. ACT is not liable for the labor involved in the unauthorized repair, or replacement costs including parts and labor. This warranty is in lieu of all other warranties, expressed or implied, written or oral. The liability of ACT shall not exceed the cost of the repair or replacement of defective parts; ACT is not liable for damages of any sort whatsoever, including incidental and consequential. There are no implied warranties of fitness for a particular purpose that apply to this product.

Owner _____
Address _____
City/St/Zip _____
Installation Date _____
Contractor _____
Address _____
City/St/Zip _____
In-Ground Model # _____
Serial # _____

**KEEP FOR YOUR RECORDS
DO NOT MAIL CERTIFICATE**

AQUA COMFORT TECHNOLOGIES, LLC
P.O. BOX 1520
SYKESVILLE, MD 21784-1520
(410) 549-6083 / Fax: (410) 549-6082

WARRANTY REGISTRATION

The Warranty Registration Form must be filled out in full and mailed to AQUA COMFORT TECHNOLOGIES, LLC within sixty days from the date of installation. Do not mail Warranty Certificate.

MAIL TO:

**AQUA COMFORT TECHNOLOGIES, LLC
ATTN: WARRANTY DEPT.
P.O. BOX 1520
SYKESVILLE, MD 21784-1520**

WARRANTY REGISTRATION HEAT PUMP POOL HEATER

Name of Owner _____ Phone _____

Address _____

City, State _____ Zip + 4 _____

Installation Date _____ Dealer _____

In-Ground Model # _____ (Location – Label on Front Panel of Unit)

Serial # _____ (Location – Label on Front Base / Bottom of Unit)

Pool Surface Area _____ ft x _____ ft

Is Pool Covered? Yes No (Circle One)

Is Pool Screened In? Yes No (Circle One)

Is an In-Line Chlorinator Used? Yes No (Circle One)

Questions / Comments

Signature _____ Date _____